

# ali

Table

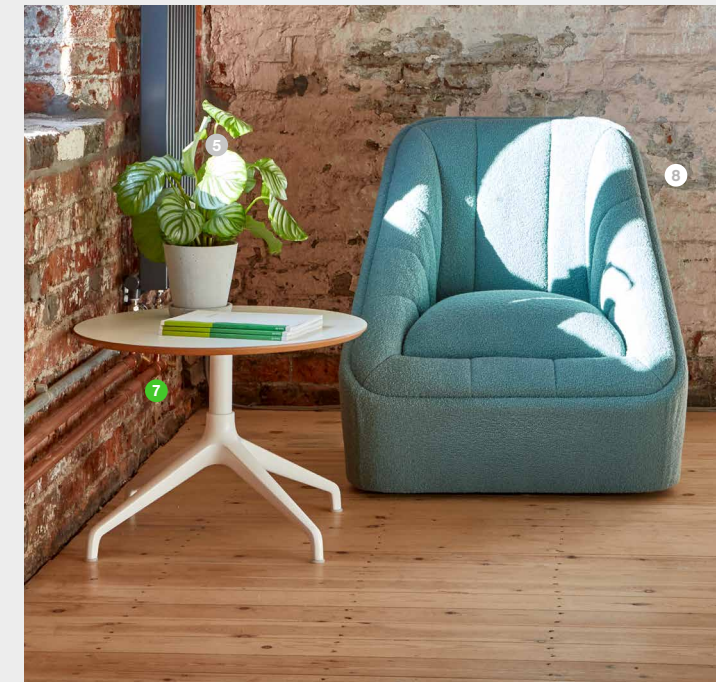
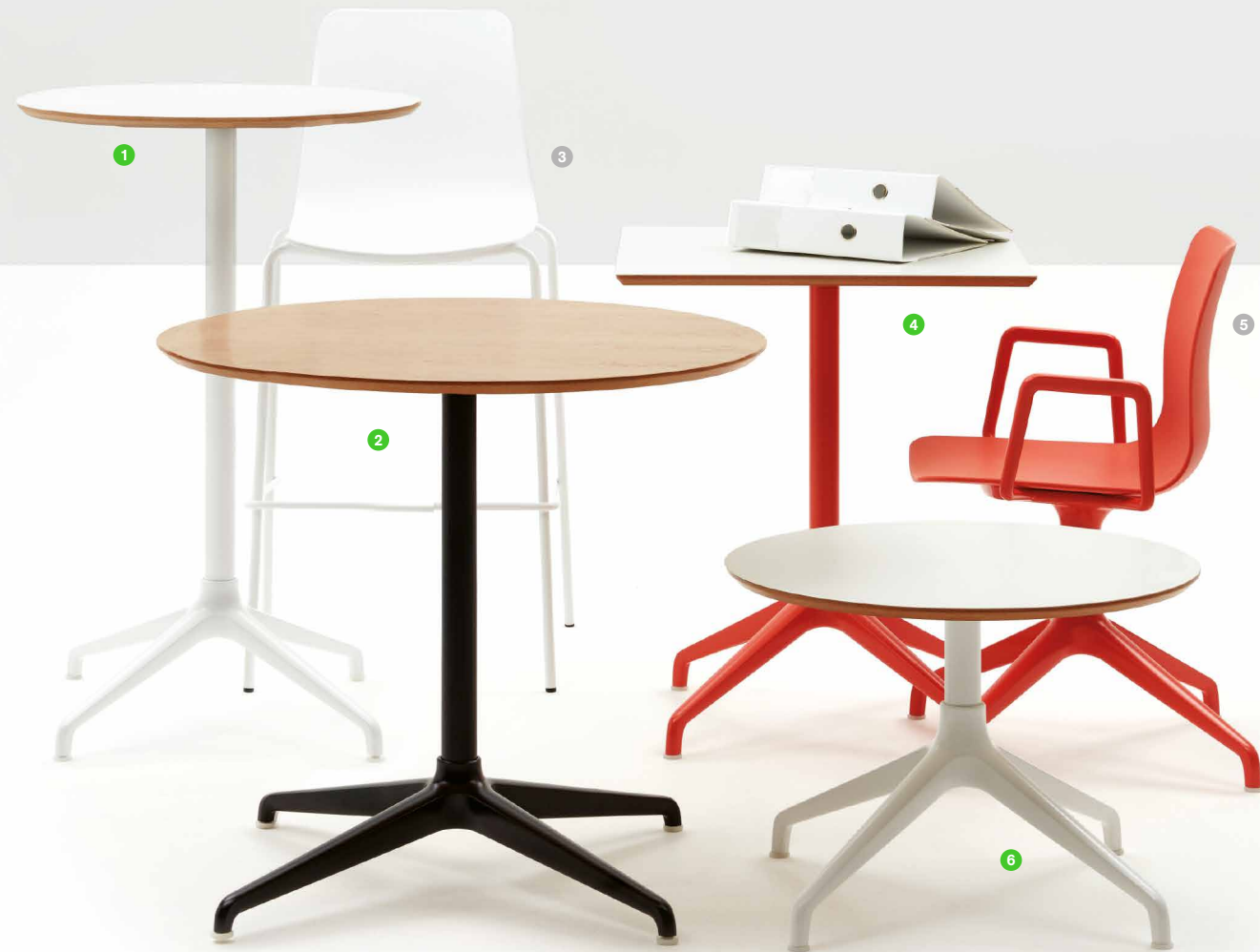

## About Ali

Ali is the most recent addition to naughtone's range of coffee, café and poseur tables, working particularly well in the hospitality and education sectors. Ali has a robust die cast aluminium base that is lightweight and perfectly complements our range of 4 star based chairs, within an abundance of environments.

## Compliance

- SCS Indoor Advantage™ Gold Certificate
- FSC®certified products available upon request
- naughtone is FISP and ISO14001 certified
- Our tables are designed to meet or exceed all EN performance requirements per BS EN 15372:2016

## Sizes

All dimensions quoted are rounded to the nearest 5mm or nearest 1/2 inch



**ALI650DL**  
Ali 650 Circular Coffee Table  
mm Dia 650 H 450  
inch Dia 25.5 H 17.5



**ALI650SL**  
Ali 650 Square Coffee Table  
mm W 650 D 650 H 450  
inch W 25.5 D 25.5 H 17.5



**ALI850DL**  
Ali 850 Circular Coffee Table  
mm Dia 850 H 450  
inch Dia 33.5 H 17.5



**ALI850SL**  
Ali 850 Square Coffee Table  
mm W 850 D 850 H 450  
inch W 33.5 D 33.5 H 17.5



**ALI650D**  
Ali 650 Circular Cafe Table  
mm Dia 650 H 750  
inch Dia 25.5 H 29.5



**ALI650S**  
Ali 650 Square Cafe Table  
mm W 650 D 650 H 750  
inch W 25.5 D 25.5 H 29.5



**ALI850D**  
Ali 850 Circular Cafe Table  
mm Dia 850 H 750  
inch Dia 33.5 H 29.5



**ALI850S**  
Ali 850 Square Cafe Table  
mm W 850 D 850 H 750  
inch W 33.5 D 33.5 H 29.5



**ALI650DH**  
Ali 650 Circular Poseur Height Table  
mm Dia 650 H 1000  
inch Dia 25.5 H 39.5



**ALI650SH**  
Ali 650 Square Poseur Height Table  
mm W 650 D 650 H 1000  
inch W 25.5 D 25.5 H 39.5



**ALI850DH**  
Ali 850 Circular Poseur Height Table  
mm Dia 850 H 1000  
inch Dia 33.5 H 39.5

## Top Options



**White / Black MFMDf**  
edge banded



**White / Black MFMDf**  
with reverse chamfer,  
polished MDF edge



**Forbo Lino**  
with reverse chamfer edge  
8 colours available



**Oak Veneer**  
with reverse chamfer,  
polished MDF edge



**Walnut Veneer**  
with reverse chamfer,  
polished MDF edge

## Base Finishes



**White Powder Coated**  
Base and Stem  
Standard



**Black Powder Coated**  
Base and Stem  
Standard



**RAL Powder Coated**  
Base and Stem  
naughtone Colours











# Ali Coffee Table Technical Specifications

## Testing

Our tables are designed to meet or exceed all EN performance requirements per **EN 15372:2008**, which includes the following tests:

- Edges of top rounded or chamfered, no burrs or sharp edges
- Shall not be possible for load bearing parts to come loose unintentionally
- Shear and squeeze points during use
- Stability under vertical force – Main surface
- Horizontal static load – High
- Vertical static load
- Horizontal fatigue
- Vertical impact for tables without glass

## Servicing



If a component is damaged and needs replacing then please email our team with an image of the damaged part and reference your order number, we will be happy to facilitate any replacements.

## Warranty



naughtone offers a **10 Year** warranty across all products. Details on the terms and conditions of naughtones warranty can be found at [naughtone.com/warranty](http://naughtone.com/warranty)

# Ali Coffee Table Technical Specifications

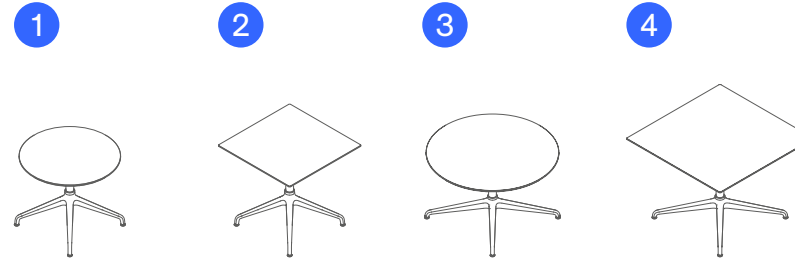

Product Code and Description <small>All dimensions quoted are rounded to the nearest 5mm or nearest 1/2 inch</small>	A Width	B Depth	C Height	D Distance from Floor to Underside Top	E Splay Of Base at Widest Point	F Weight
<b>1</b> <b>AL1650DL</b> Ali 650 Circular Coffee Table	650 mm 25.5 in	650 mm 25.5 in	450 mm 17.5 in	432 mm 17 in	705 mm 28 in	10.2 kg 22.5 lbs
<b>2</b> <b>AL1650SL</b> Ali 650 Square Coffee Table	650 mm 25.5 in	650 mm 25.5 in	450 mm 17.5 in	432 mm 17 in	705 mm 28 in	11.5 kg 25.4 lbs
<b>3</b> <b>AL1850DL</b> Ali 850 Circular Coffee Table	850 mm 33.5 in	850 mm 33.5 in	450 mm 17.5 in	432 mm 17 in	865 mm 34 in	14.5 kg 31.9 lbs
<b>4</b> <b>AL1850SL</b> Ali 850 Square Coffee Table	850 mm 33.5 in	850 mm 33.5 in	450 mm 17.5 in	432 mm 17 in	865 mm 34 in	15.9 kg 35 lbs

## Measuring Guide

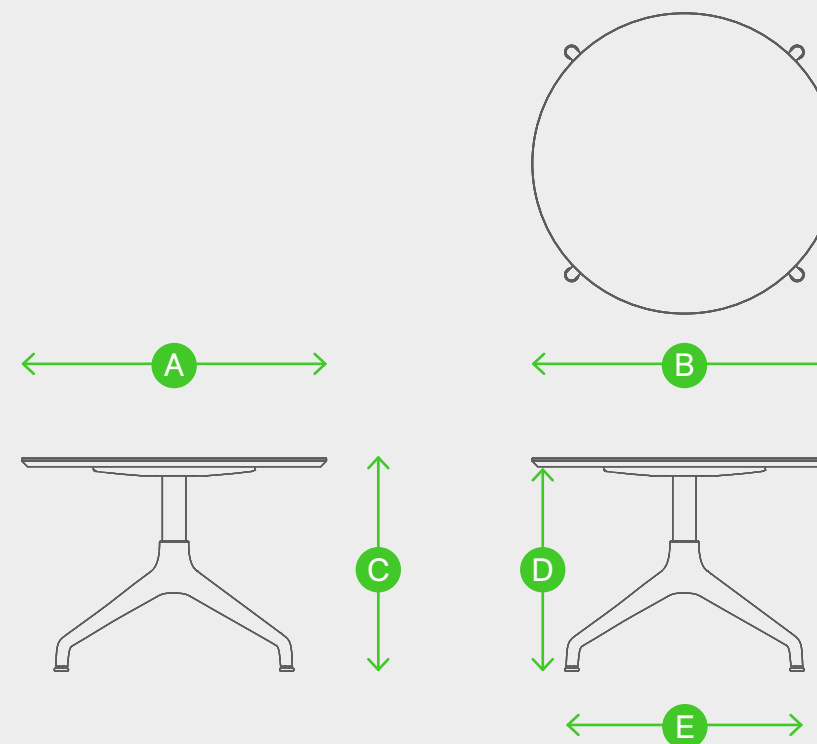

## Ali Cafe Table Technical Specifications

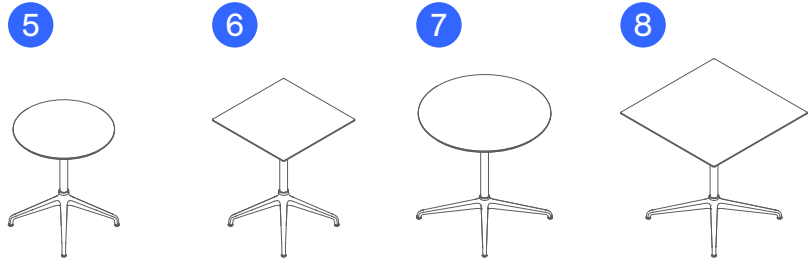

Product Code and Description <small>All dimensions quoted are rounded to the nearest 5mm or nearest 1/2 inch</small>	A Width	B Depth	C Height	D Distance from Floor to Underside Top	E Splay Of Base at Widest Point	F Weight
<b>5</b> NOALI2C650 Ali 650 Circular Table	650 mm 25.5 in	650 mm 25.5 in	750 mm 29.5 in	732 mm 30 in	705 mm 28 in	10.75 kg 23.7 lbs
<b>6</b> NOALI2SQ650 Ali 650 Square Table	650 mm 25.5 in	650 mm 25.5 in	750 mm 29.5 in	732 mm 30 in	705 mm 28 in	12.1 kg 26.7 lbs
<b>7</b> NOALI2C850 Ali 850 Circular Table	850 mm 33.5 in	850 mm 33.5 in	750 mm 29.5 in	732 mm 30 in	865 mm 34 in	15.1 kg 33.3 lbs
<b>8</b> NOALI2SQ850 Ali 850 Square Table	850 mm 33.5 in	850 mm 33.5 in	750 mm 29.5 in	732 mm 30 in	865 mm 34 in	17.4 kg 38.4 lbs

### Measuring Guide

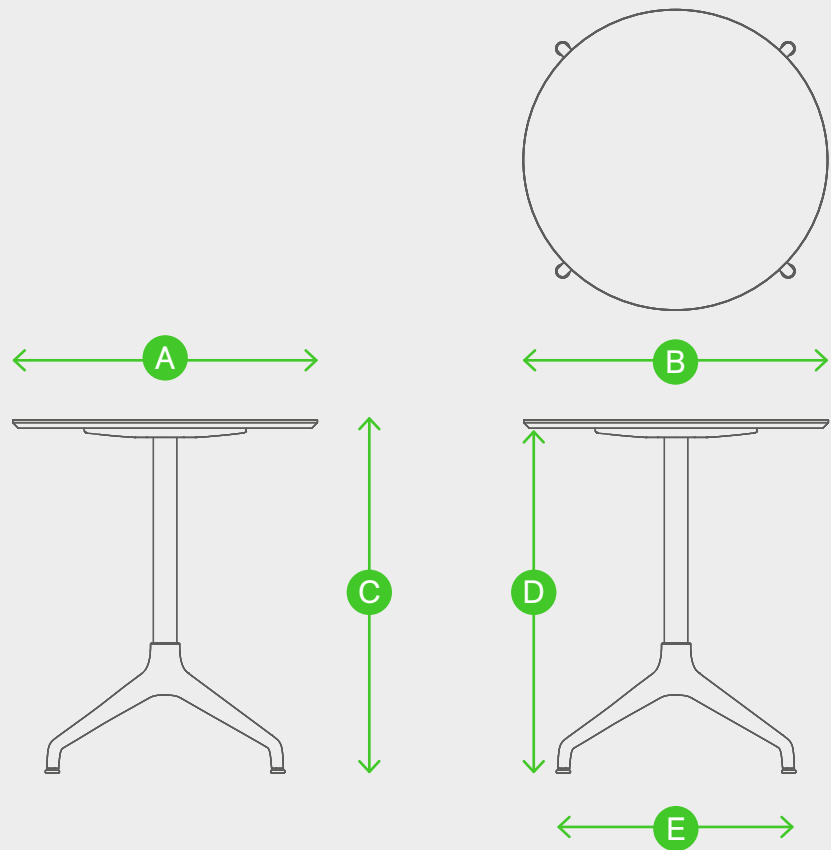

## Ali Poseur Table Technical Specifications

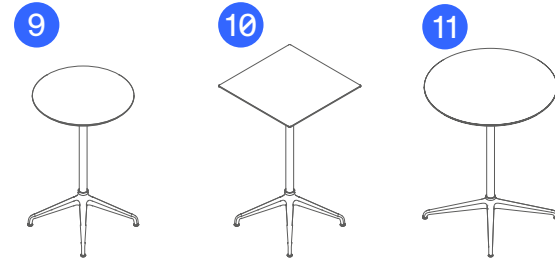

Product Code and Description <small>All dimensions quoted are rounded to the nearest 5mm or nearest 1/2 inch</small>	A Width	B Depth	C Height	D Distance from Floor to Underside Top	E Splay Of Base at Widest Point	F Weight
<b>9</b> NOALI3C650 Ali 650 Circular Poseur Table	650 mm 25.5 in	650 mm 25.5 in	1000 mm 39.5 in	982 mm 38.5 in	705 mm 28 in	11.2 kg 24.7 lbs
<b>10</b> NOALI3SQ650 Ali 650 Square Poseur Table	650 mm 25.5 in	650 mm 25.5 in	1000 mm 39.5 in	982 mm 38.5 in	705 mm 28 in	12.5 kg 27.6 lbs
<b>11</b> NOALI3SQ850 Ali 850 Circular Poseur Table	850 mm 33.5 in	850 mm 33.5 in	1000 mm 39.5 in	982 mm 38.5 in	865 mm 34 in	15.7 kg 34.6 lbs

### Measuring Guide

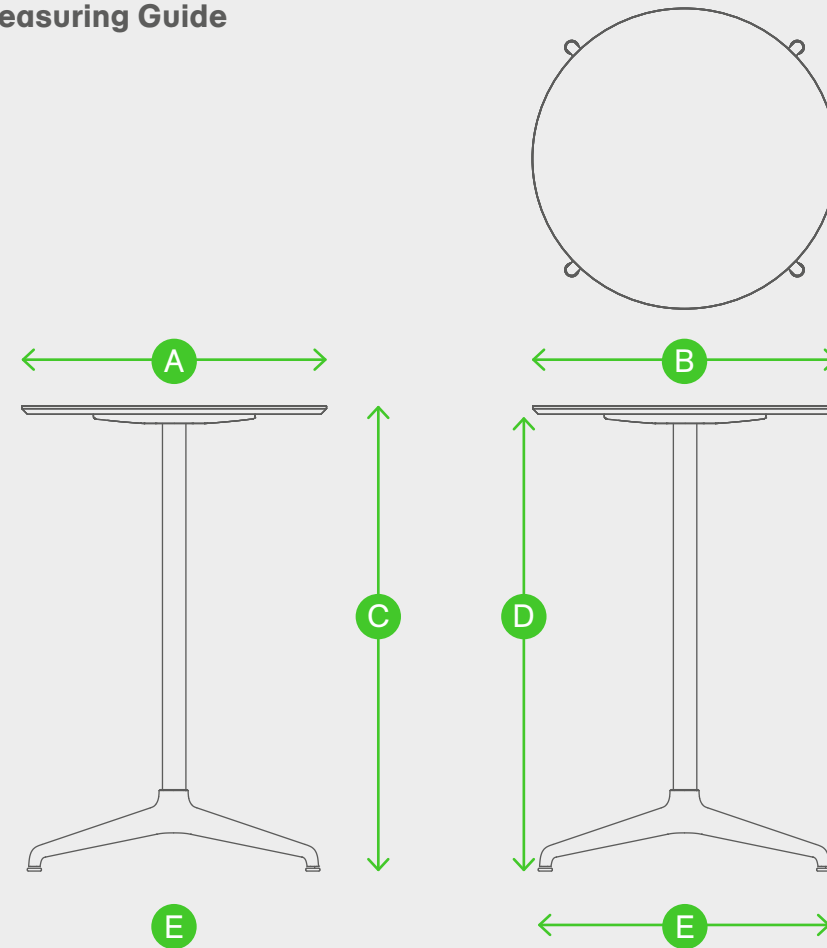



# Ali Table Environmental Product Summary



## Environment Attributes

- naughtone is **FISP** and **ISO14001** certified
  - naughtone is **FSC®** certified
  - **15.1kg** total weight
  - **48.7% Recyclable** (base and fixings)
  - **51.3% Reusable** (top)
  - **39.4% Recycled content** (base and fixings)
  - **Packaging:** 77.5% recycled cardboard 22.5% virgin fibre and protective biodegradable bubble wrap
  - **Indoor Advantage™ Gold** ANSI/BIFMA Furniture Emissions Standard (M7.1/X7.1-2011 R2016) and ANSI/BIFMA e-3-2014e (Credits 7.6.1, 7.6.2, 7.6.3)
- These attributes can help you to achieve criteria towards **LEED**, **BREEAM**, **Ska** and **WELL** building certifications



# Ali Table Environmental Product Summary

## Material Percentage Split

- 48.7% Melamine Faced MDF
- 26.7% Aluminium
- 18.8% Mild Steel
- 0.7% Stainless Steel
- 0.1% Polyethylene

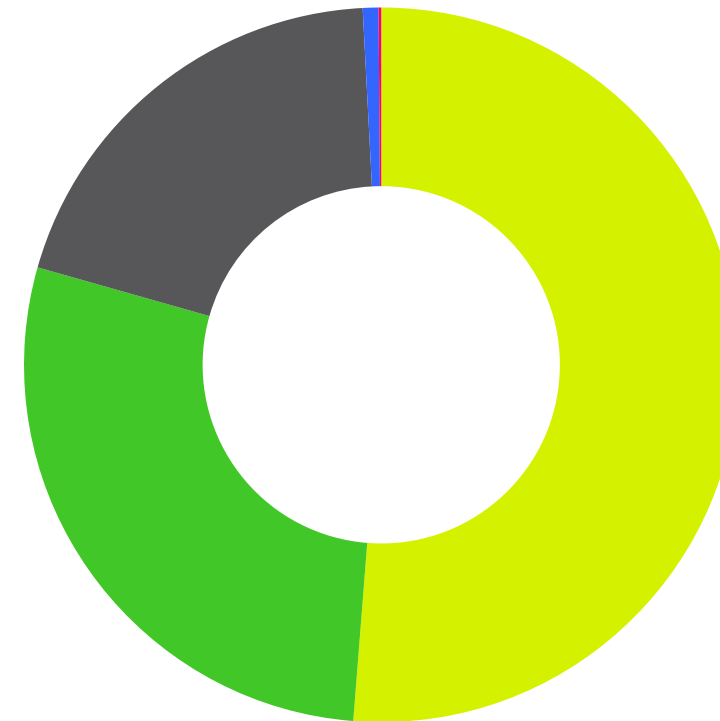

## Post Consumer Recycled Content

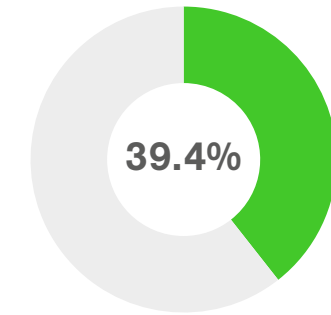

## Recyclable Content

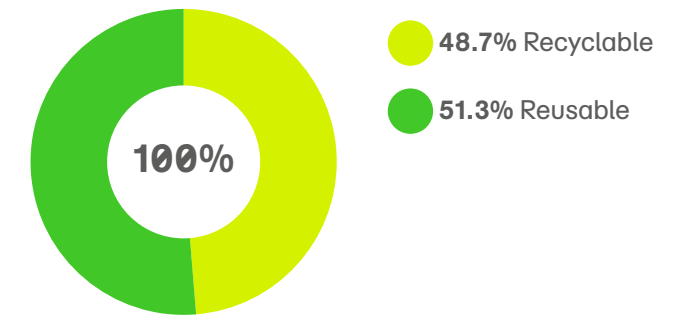

## Product Specific Design Statement

The **Ali** table is available in a range of sizes and finishes but for the purpose of this document we have a specific example from the range:

### Ali 850 Circular Cafe Table with White MFMDf Top

The **Ali** table 4 star base is made from die cast aluminium. The stem and top plate are manufactured from mild steel with the surface of the base then finished with a polyester powder coat.

The table top is made from MFMDf and the raw edge is polished and finished with a hard-wearing spray lacquer.

## CSR Statement

naughtone has always considered the environment throughout our design and manufacturing process. We understand that as we continue to grow, so does our potential impact on our surroundings. As most of our raw materials are simple, we have great control over their sources, and are proud to be able to offer **FSC®certified** upholstered products and use recycled metals in our table ranges. The addition of our North American manufacturing provision also helps to keep manufacturing miles to a minimum, as our market continues to grow in the USA. Finally, naughtone offers a 'bring back' programme, where the client is able to return the product to our factory, where we will be happy to breakdown and recycle the parts for you.

Where sustainable sources are quoted, and a chain of custody is required by a customer this must be indicated on the purchase order to naughtone. A chain of custody requested after an order has been placed or delivered may be difficult to recover. Figures stated in the Environmental product summary may vary based on model and options selected, we have based this document on a specific example when produced in the United Kingdom. Recycled content calculations are taken from supplier information and industry averages, material variables are likely to affect the figures which may result in higher or lower percentages. This document will be reviewed and updated periodically and is subject to change without notice.





### 1 Design

Every aspect of the naughtone product ranges has been designed with the environment considered, from ethical material choice and production efficacy to storage efficiency and ease of disassembly.

Dense foam sets and resilient fabrics are selected for their longevity and effectiveness across sectors. Durable high quality finishes such as powder coated bases in a range of colours allow clients the freedom of finish options. Finish samples are available allowing clients to make informed decisions and retain to add to their finish libraries for future reference.

### 2 Raw Material

Local supply of raw materials is employed for the production of our products when possible, procured from suppliers that are quality inspected for extraction methods and meet the highest environmental standards.

### 3 Production

As many of our products are assembled by hand the energy expenditure wasted from machinery during the production process is kept to a minimum.

All fabrics are cut to ensure optimum efficiency with fabric usage and reduced waste consumption per unit.

All production sites have recycling facilities for any excess product that cannot be used elsewhere, which is then managed by a professional third party.

### 4 Distribution

Distribution of naughtone products generally occurs directly between the manufacturing site to the client. Production is localised when possible to the US or UK regions, reducing the carbon footprint and miles travelled for each product.

Many items are flat packed for delivery or shipped disassembled with efficient, minimised packaging; optimizing the transportation vessel space.

### 5 Usage

naughtone products do not require energy or water to function, thus no environmental exchange takes place and no waste is generated during the life of the product.

The only foreseeable need is the cleaning of the product for general maintenance. This includes regular vacuuming to remove dirt and dust particles on upholstery items, and using a dry or damp cloth to wipe non-upholstery items.

This is recommended for all products utilised under conditions of normal wear and is expected to have negligible environmental impacts.

### 6 End of Life

Although our products are durable and demonstrate timeless design, naughtone products are manufactured in such a way that they can be easily disassembled at the end of life and most of the componentry can be either recycled or re-used as applicable.

As a company we are also happy to accept the return of products, to help re-home or recycle furniture or components at the end of the products useful life.

#### UK Showroom

6 Bakers Yard  
Clerkenwell  
London EC1R3DD  
T: +44 (0)20 389 22 788

#### US Showroom

Suite 11-88  
222 Merchandise Mart Plaza  
Floor 11  
Chicago IL 60654

#### naughtone HQ

Knaresborough Tech Park  
Manse Lane  
Knaresborough HG5 8LF

T: +44 (0) 1423 816 500  
E: sales@naughtone.com

[www.naughtone.com](http://www.naughtone.com)